

ELECTRA BERYLLIUM 1000 Series

User manual

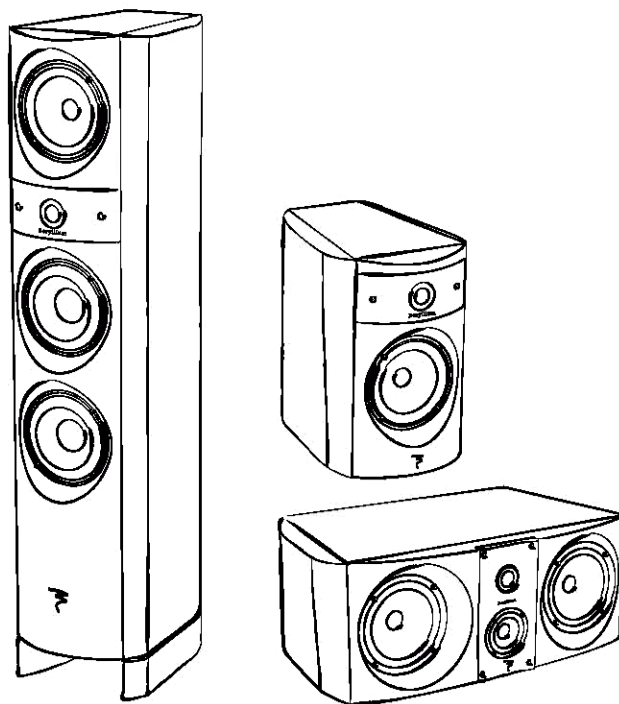

USER PRECAUTIONS

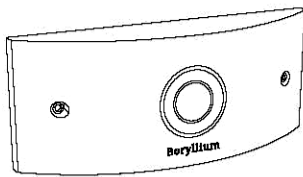

Thank you for choosing the Electra Be loudspeakers. We are pleased to share with you our philosophy: "the Spirit of Sound". These high performance speakers feature the latest technical developments from Focal in terms of speaker design, whether it is for high fidelity or home theater systems. In order to (make the most of these speakers) enjoy the maximum of their performance, we advise you to read this user's manual and to keep it carefully so that you can consult it later.

Special precautions regarding the Beryllium dome tweeter

In its solid form, Beryllium is harmless. However, due to its nature, certain special precautions should be observed to avoid exposure to unnecessary risk.

- Under no circumstances should the Beryllium dome be subjected to any form of abrasive action. To ensure no accidental damage to the tweeter dome it is advised to carefully replace the magnetic protection grille.
- In the unlikely case of damage to the dome, of any form, the supplied piece of adhesive tape should be immediately used to seal the whole front surface of the tweeter. The protective cover should then be replaced and also taped securely in place. You should then inform the dealer from whom you purchased the product so that the tweeter can be removed by a professional and returned to the product distributor for replacement.
- If the dome is broken in any way giving rise to loose particles of Beryllium, these should be carefully collected with the use of an adhesive tape and sealed in a zip-top bag to be returned with the tweeter. For further information, please contact Focal-JMLab directly: beryllium@focal-fr.com

Magnetic disturbance

The Electra Be line speakers generate a magnetic leakage that may interfere with other sensitive household appliances. It is strongly advised not to place the speakers closer than 50cm to your TV screen. Frame geometry as well as colours can be severely distorted by a magnetic field if the loudspeaker is placed too close to the cathode ray tube.

Generally, every sensitive element (audio tapes, video tapes, magnetic data storages, projector and CRTS overhead-projector) should not be placed too close to non-shielded loudspeakers.

User precautions

All the products in the Electra Be range are lacquered in order to offer a resistant cabinet surface and to make the upkeep easy. We recommend the use of a dry cloth to dust your pair of loudspeakers. If the loudspeaker is stained, then use a damp cloth.

Never use any solvents, detergents, alcohol or corrosive products, scrappers or scouring powder to clean the surface of the loudspeaker. Avoid placing the loudspeakers near a heat source.

ELECTRA Be USER MANUAL

The Focal-JMLab guarantee only applies if the enclosed guarantee card is returned to us within 10 days of purchase.

Running-in period

The drivers used in the loudspeaker are complex mechanical devices and require an run-in period before they deliver their best performance. They must get adapted to the temperature and humidity conditions of their environment. This breaking-in period depends on the encountered conditions and can last several weeks. In order to shorten this period, we advise you to let your loudspeakers operate for about twenty hours at medium level, playing standard musical programmes, but with a large amount of bass.

Once the components of the loudspeakers are completely stabilized, it is possible to enjoy the real performance of your loudspeakers.

Specifications

- Pure Beryllium inverted dome IAL (Infinite Acoustic Loading).
- "W" cone (midrange and woofer).
- Advanced "Gamma" structure.
- OPC (Optimum Phase Crossover).
- Low distortion and noise laminar port.
- Highly efficient acoustic damping.
- High reliable input sockets.
- Decoupling spikes supplied.

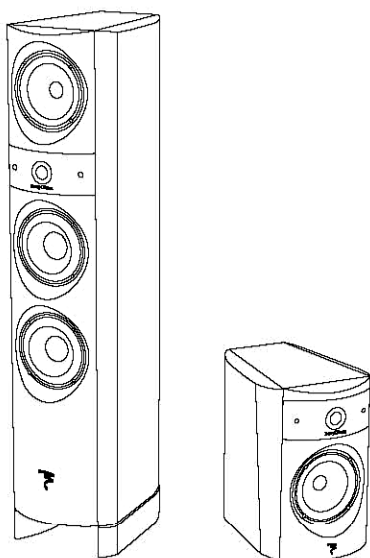

Focal-JMLab® - BP 374 - 108, rue de l'Avenir - 42353 La Talaudière cedex - France - www.focal-fr.com
Tel. (+33) 04 77 43 57 00 - Fax (+33) 04 77 43 57 04

Due to constant technological advances, Focal reserves its right to modify specifications without notice. Images may not conform exactly to specific product.



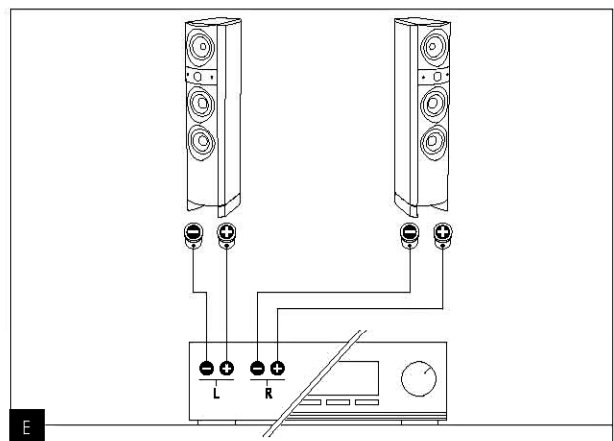
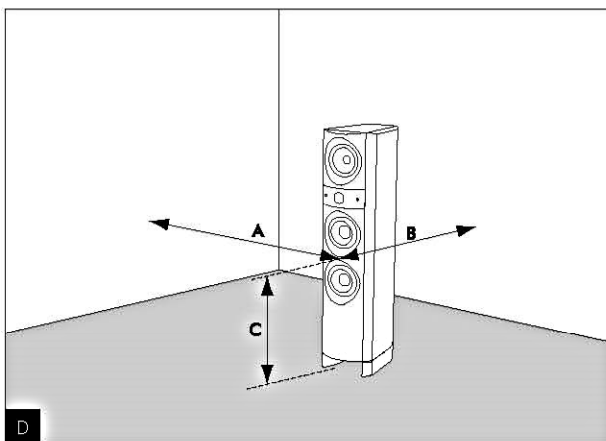
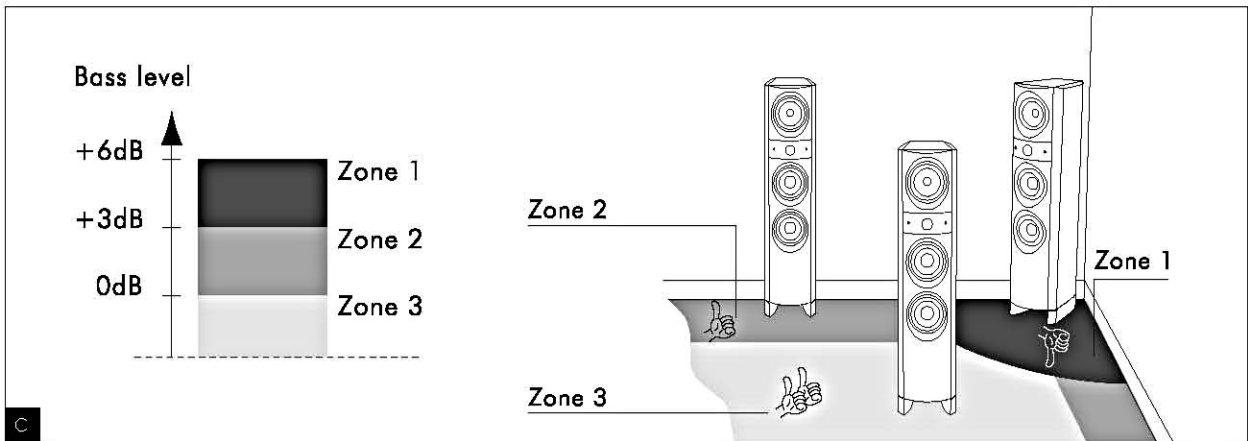
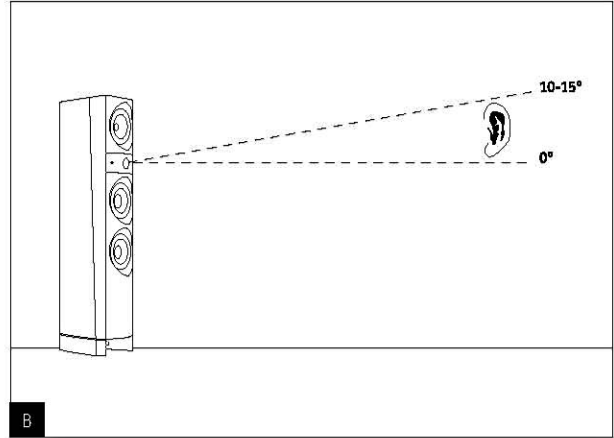
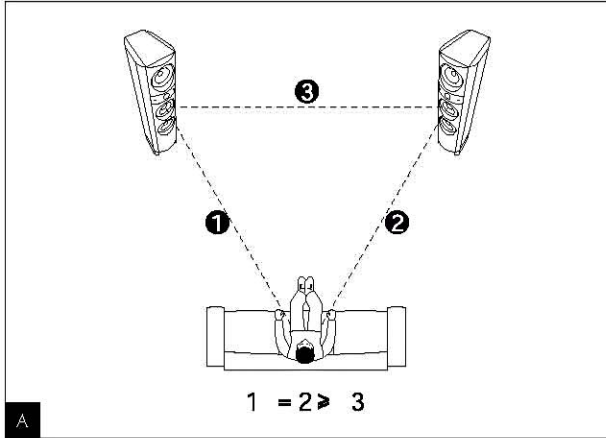

INSTALLATION

Positioning

The loudspeakers have been engineered to deliver the most faithful sound reproduction, whether they are used for music or home cinema. In order to enhance their performance, to guarantee a high quality of listening, sound image and tone balance, it is important to note the following basic rules.

The listening area must be located at the summit of an equilateral triangle whose two other points of insertion are determined by the position of each speaker. Nevertheless it is possible to modify these distances to find an ideal compromise according to the particular disposition of the room (*fig. A*).

Each loudspeaker must be placed at the same height and on the same floor plan. The tweeter should be at the same height as the listener's ear, when the listener is in their usual listening area (*fig. B*).

Avoid placing the loudspeakers too close to the room's corners or walls. This will induce some unwanted room resonance and artificially increase bass response. On the contrary, if the bass level proves to be insufficient, it is possible to move the speakers closer to the walls to adjust the bass level (*fig. C*).

Optimization

To please the perfectionists, we shall give an optimum positioning formula : if **A** is the distance from the boomer centre to the closest wall (floor or wall), **B** the intermediate distance and **C** the longest distance (**A < B < C**), the relation **$B^2 = AC$** determines the ideal position of the speakers (*fig. D*).

• Example 1:

The boomer centre is 60cm (24") from the floor (**B=60cm**) (mini speaker on a foot), standing 50cm (20") from the back wall (**A=50cm**), the side wall will be ideally 72cm (28") (**$C = B^2 / A = 72\text{cm}$**).

• Example 2:

the boomer centre is 30cm (12") from the floor (column speaker) (**A=30cm**), 1m (39") from the back wall (**C=1m**), the clearance with respect to the side walls will be **$B = \sqrt{AC} = 54.7\text{cm}$** (22").

Important

Stylish driver protective caps conjoined to the loudspeaker. Do not remove for optimized performances.

Connections

The Electra Be input sockets ensure reliable multipurpose connections for stripped cables as well as for plugs.

It is imperative to respect the connector polarity of both the loudspeaker and amplifier. The positive terminal "+" must be connected to the corresponding (matching) amplifier's terminal and the negative terminal "-" to the negative terminal (*fig. E*). Stereo image, soundstaging and bass perception would be seriously compromised if these conditions were not respected.

User instructions

The sound rendition of the loudspeaker depends strongly upon the listening room's acoustics, the place of the loudspeakers and the listening area. These factors can be modified in order to correct or enhance a desired effect.

Should the soundstage be imprecise or not centred, try to move the loudspeakers closer to each other.

Harsh or aggressive sound means that your listening room is probably too reflective. Try to use any absorbing materials (such as tapestries, sofa, wall coverings, curtains...) combined with reflective materials to absorb or diffuse resonances.

Should the sound be "flat" or muffled, there are too many absorbing materials in the listening room. The sound appears to be closed-in, with a narrow stereophonic image. Try to find a better compromise between absorbing and reflective materials within your listening room.

Generally the wall to the rear of the speakers should be made up of reflective materials so that the sound image exhibits satisfying volume and width. On the contrary the wall on the rear of the listener should be absorbing in order to avoid reflections damaging the perception of the stereo soundstage. These reflections may limit the impression of depth of the sound image. Furniture, such as bookshelves should be ideally placed along the side walls in order to diffuse sound waves and to prevent some frequencies from being amplified, especially in vocal range (it removes "flutter echo").

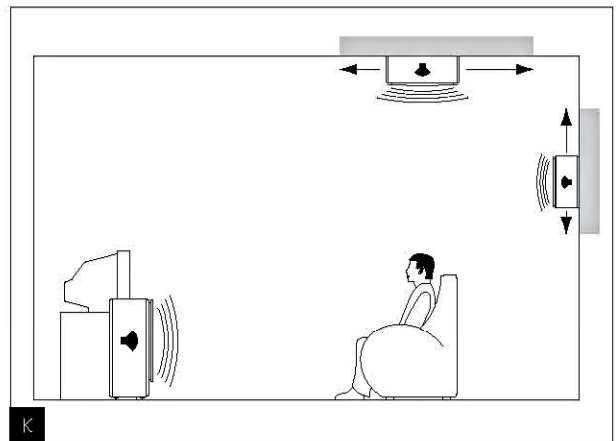
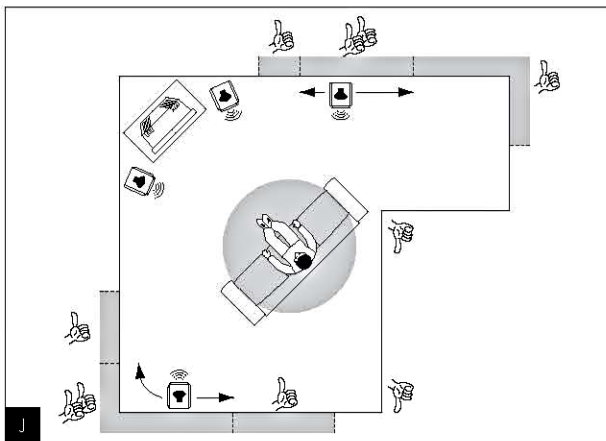
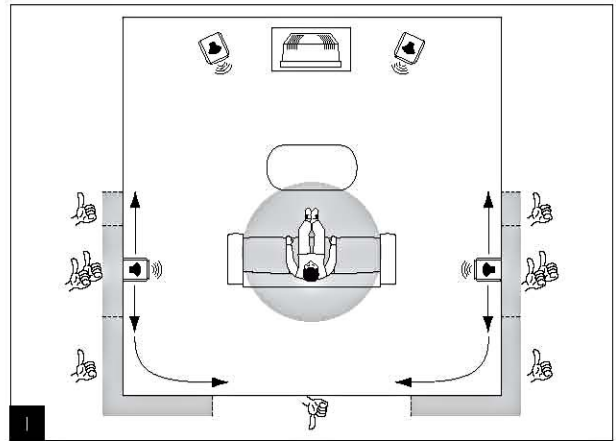
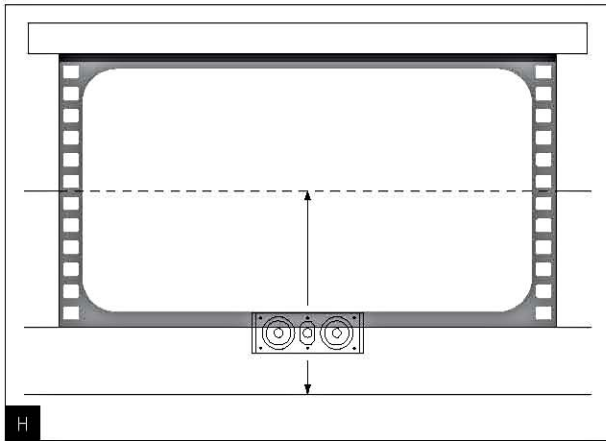
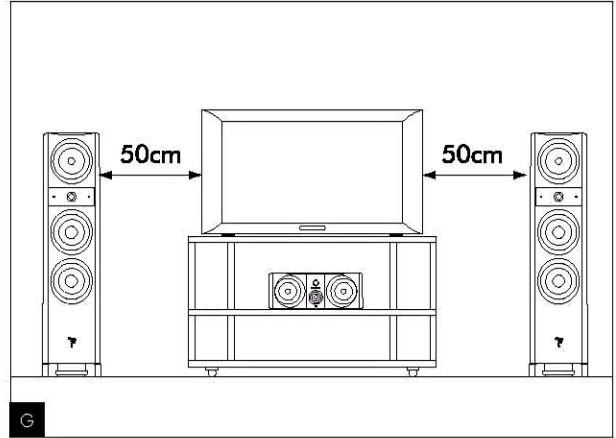
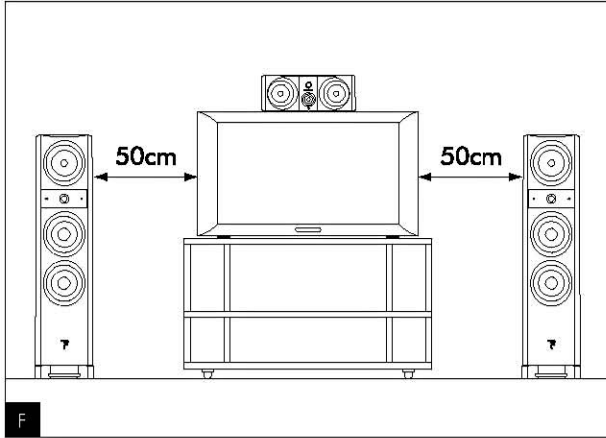

HOME THEATER

Choice of speakers

Your loudspeakers have been engineered to work with stereo systems as well as with home theater systems. If you already own a pair of stereo Electra Be loudspeakers and wish to purchase a complete home theater system, it is of the utmost importance that you use the central and effect loudspeakers of the same product line. It is the sole possible condition to bring to your system a perfect tonal homogeneity and a realistic and coherent reproduction of tri-dimensional effects within the listening room.

Central channel placement

Central channel speakers should be placed close to the TV-screen to obtain a proper placement and a realistic reproduction of the dialog. They could be placed below or above the TV-screen if your TV-unit permits (**fig. F, G**).

If a standart projection screen is used, the central channel speaker must be placed under the screen.

If an acoustically transparent projection screen is used, the central channel speaker can be placed behind and at the bottom of the screen (**fig. H**).

Effect channel speakers's place

The soundtrack mix for a film or music encoded in multichannel format is very complex and allows the listener to benefit from a wide range of special sound effects, which require the use of effect channel speakers. In order to obtain a realistic 3D soundstage, the placement of the speakers is decisive, even when confronted with a restrictive disposition of the listening room. For enhanced performances, the following elements should be noted.

Avoid placing the effect speakers too far from the listening area otherwise the sound perception will be altered. In order to obtain surround effects, with great sound density we advise you to place the speakers against the sidewalls on each side of the listening room (**fig. I, J**).

Place the effect speakers at a suitable height, slightly above the listener's ears (**fig. K**).

A / V amplifiers include compensation systems, which allows to set the delay applied on each channel. In certain conditions, the distance between each speaker and the listening area may vary.

The latest high-level film soundtracks are now mixed in 6.1. This system requires the use of one or two central surround channel speakers (depending on the amplifier) which should be placed behind the listening area. If two effect speakers are used simultaneously, make sure that they are not too far from each other (less than one meter; 40 inches) in order to obtain the best results.

FINE TUNE

Accessories

Floorstanding loud-speaker systems include four decoupling spikes and four butyl cone and could be screwed, if necessary, into the four metal inserts situated on the base of the loudspeaker. These spikes ensure a better stability for floorstanding speakers, particularly if the floor is not perfectly flat and smooth. This stability improves clarity in bass and midrange by decoupling the system from the floor and thus reducing floor-born resonances. This required stability allows the energy delivered by the woofer's membrane to be integrally converted into sound. The enclosed spikes are adjustable in height. After having adjusted the height of the spikes, don't forget to lock them with the locknut.

When the use of the spikes proves to be necessary, we advise you to place a piece of metal (such as a coin) between the floor and the spike in order to avoid scratching a tiled floor. Bookshelf speakers can be placed on an optional stand specially developed for them.

About amplifiers

Contrary to what one might think, it is not a too powerful amplifier that might damage a loudspeaker, but rather a lack of power. Actually if the output level of the amplifier is too high it will saturate and distort which will irretrievably damage the tweeter.

The power handling and frequency response of the loudspeakers is good enough to highlight the qualities or weak points of the amplifiers they are combined with. Let your retailer help you make the right choice, matching your personal taste and budget.

Cable

Don't underestimate the importance of the cable: make sure you chose the appropriate section and length. Let your retailer advise you.

Conditions of guarantee

All Focal loudspeakers are covered by guarantee drawn up by the official Focal distributor in your country.

Your distributor can provide all details concerning the conditions of guarantee. Guarantee cover extends at least to that granted by the legal guarantee in force in the country where the original purchase invoice was issued.

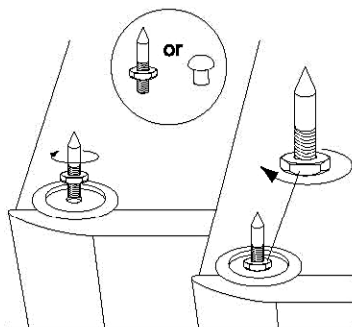

SPECIFICATIONS

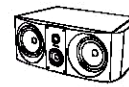
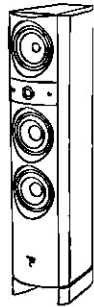

	Electra 1027 Be	Electra 1007 Be	Electra CC 1000 Be
Type	3-way bass-reflex floor standing loudspeaker	2-way bass-reflex bookshelf loudspeaker	3-way bass-reflex shielded center channel
Drivers	1" pure Beryllium IAL inverted dome tweeter 6-1/2" "W" cone midrange, 1-1/4" voice coil Two 6-1/2" "W" cone woofer, 1-1/2" voice coil	1" pure Beryllium IAL inverted dome tweeter 6-1/2" "W" cone mid-bass, 1-1/4" voice coil	1" pure Beryllium IAL inverted dome tweeter 3" "W" cone midrange, 1" voice coil Two 6-1/2" "W" woofers, 1" voice coil
Cut-off frequency (-6dB)	30Hz	41Hz	50Hz
Frequency response (-3dB)	38Hz to 40kHz	46Hz to 40kHz	55Hz to 40kHz
Sensitivity (2.83V/1m)	91dB	89dB	91dB
Nominal impedance	8Ω	8Ω	8Ω
Minimum impedance	3.5Ω at 120Hz	3.9Ω at 200Hz	4.1Ω at 136Hz
Max Power handling	200 Watts	90 Watts	150 Watts
Crossover frequency	350Hz / 2000Hz	2000Hz	500Hz / 2000Hz
Dimensions (HxWxD)	43-11/16x10-3/8x13-3/4" (1110x264x350mm)	15-3/16x10-3/8x10-3/4" (385x264x350mm)	9-1/4x24x13-3/4" (235x609x350 mm)
Net weight	72.6lbs (33kg)	33lbs (15kg)	41.8lbs (19kg)